

INFORMATION

Support News 

April 3, 1995

Volume I, Issue 24

“Get Off the Highway
and Into the Alley™”



In This Issue...

Inside Information	2
Thoughts From the Alley Cat – MacWorld Reviews Information Alley	3
System 7.5 – Failure After Partial Installation	4
Creating a Slide Show With Apple Media Tool	5
Extension Versions Inconsistent After Installing System 7.5 Update 1.0	6
Macintosh to Performa Comparison Chart	7
Long Startup Times With System 7.5	8
Known Issues With QuickDraw GX Helper	9
Hard Drive Buzzing	10
System 7.5 Update 1.0 – PC Setup 1.0.2 Not Compatible with DOS Compatible Systems.....	11
4MB Extended Density Floppy Disk Formats as 800K	12
Why the Apple IP Gateway Cannot See Other Clients on the Same Server	13
LaserWriter 16/600 PS – Changing Paper Options Using PCL	14
The Apple Mobile Messaging System	15
StyleWriter II Controls and Status Lights	19
Tell Us What You Think	20

Inside Information...

About the *Information Alley*

The *Information Alley*™ is a publication of Apple Computer, Inc., Support Information Services. The goal of the *Information Alley* is to help you get full use of your Apple computers, peripherals, and software. We make every attempt to include articles that have the broadest audience possible. However, we do sometimes print articles that do not apply to our international readers.

Where to Find the *Information Alley*

The *Information Alley* is available through a variety of online services and Internet list server capability. For a complete list of where to find the *Information Alley*, call the Apple Fax line at 1-800-505-0171 and request document #20720. You can also get an index to back issues by requesting document #20719.

Optionally, you can search the Technical Information Library; use "information alley" as the search string. Select article title
Information Alley: Online Services it is Posted To or article title ***Information Alley: Index of Past Issues***.

Submissions and Letters

We welcome articles that help Apple computer users become more knowledgeable about the functionality of their systems, explain or illustrate complex features or functions, or that describe technical tips or techniques.

Send submissions to:

Information Alley
 Apple Computer
 1200 East Anderson Lane
 MS 212-STI
 Austin, TX 78752

Fax: (512) 908-8018
 e-mail: alley@apple.com

We welcome letters to the editor and suggestions for future articles. Please do not send us your support questions.

Copyright Notice

This newsmagazine is copyrighted, with all rights reserved. Individual articles in this newsmagazine may be reprinted, in their entirety, without prior written permission from Apple as long as full credit is given to Apple Computer and the *Information Alley* is listed as the source of the information.

You must have prior written permission from Apple Computer to excerpt or paraphrase portions of articles from this newsmagazine. For permission, contact: Janet Christian, Editor or call (512) 908-8975.

Trademarks

The Apple logo is a trademark of Apple Computer, Inc., registered in the U.S. and other countries.

Apple, the Apple logo, APDA, AppleLink, AppleShare, AppleTalk, A/UX, EtherTalk, HyperCard, HyperTalk, ImageWriter, LaserWriter, LocalTalk, Macintosh, and ProDOS are trademarks of Apple Computer, Inc., registered in the U.S. and other countries.

Apple Desktop Bus, Balloon Help, Disk First Aid, Finder, SuperDrive,

Information Alley, "Get off the Highway and Into the Alley", and TrueType are trademarks of Apple Computer, Inc.

Classic is a registered trademark licensed to Apple Computer, Inc.

AppleCare is a service mark of Apple Computer, Inc., registered in the U.S. and other countries.

All other products mentioned in this newsmagazine are trademarks of their respective companies. Mention of third-party products is for informational purposes only and constitutes neither an endorsement nor a recommendation. Apple assumes no responsibility with regard to the performance of these products.

Apple Computer, Inc., products (hardware and software) described in this newsmagazine are subject to update and change. This newsmagazine makes no assurance that functions and technical information described here is not superceded by subsequent releases of the product described.

The *Information Alley* is produced using FrameMaker 4.0 on a Power Macintosh running System 7.5. 

Published bi-weekly by
Apple Computer, Inc.
Support Information Services
1200 East Anderson Lane
MS: 212-STI
Austin, TX 78752
(512) 908-8975

Janet Christian, Editor

Regular Columnists:

Wayne Brissette
 Janet Christian
 Leslie Dolan
 Diana Ezell
 Mark Hansen
 Fred Widmer



If you print the *Alley*, please share when done!

© 1994-95 by Apple Computer, Inc.



MacWorld Reviews Information Alley

By Janet Christian

The ***Information Alley*** received a very nice write-up in the May edition of ***MacWorld*** magazine. David Pogue (The Desktop Critic) wrote his May column about electronic Macintosh magazines. David wrote a nice description of the ***Information Alley*** and even provided sample article titles from recent issues.

Since the May edition of ***MacWorld*** hit the newsstands, we have received dozens of inquiries about how to find/subscribe to the ***Information Alley***. If you are one of the recent people to find your way into our alley, we welcome you to our ever-growing ranks.

We couldn't have asked for a better review – except that he credited the “backstage gurus in Cupertino” instead of us hard-working folks here in Austin, Texas.

David indicated that the ***Information Alley*** is a biweekly publication; we've always referred to it as a bimonthly publication. This leads to the ongoing dilemma...

Is it Biweekly or Bimonthly? Things to Make You Say, “Hmmm...”

I've wondered this one for a while. We publish the ***Information Alley*** every two weeks. If you check the dictionary (I used the *American Heritage College Dictionary*) you find the definition of biweekly is “happening every two weeks or happening twice a week” while the definition of bimonthly is “happening every two months or happening twice a month.” I guess I'll continue using bimonthly; I don't think I could publish something that came out biweekly.

Software Updates Column

Starting in the next issue, we will include a regular list of all software updates posted since the previous issue to online services. This way, you can easily know what is available without having to log onto the services and scouting around for yourself.

You can always find what software has recently been posted by checking the Technical Information Library article titled *What's New on Apple Software Updates*. Check the article titled *Where to Find Apple Software Updates* for a complete list of the online locations where the software is available.

Updated Feedback Form

Now that we are also offering the ***Information Alley*** in SeText format, we've modified the **Tell Us What You Think** form on page 20 to include this format in the list. 🍏

System 7.5 – Failure After Partial Installation

By Gayle Bauscher

This article describes what to do if you are installing System 7.5 from CD or floppy disks, get part way through the installation, then an error message asks you to insert Disk 1. This error message is followed by another error message saying the installation could not be completed.

The Installer always asks for Disk 1 to be inserted if it finds a problem during the installation process, this behavior is normal. The error message is actually contained in the Installer code on Disk 1.

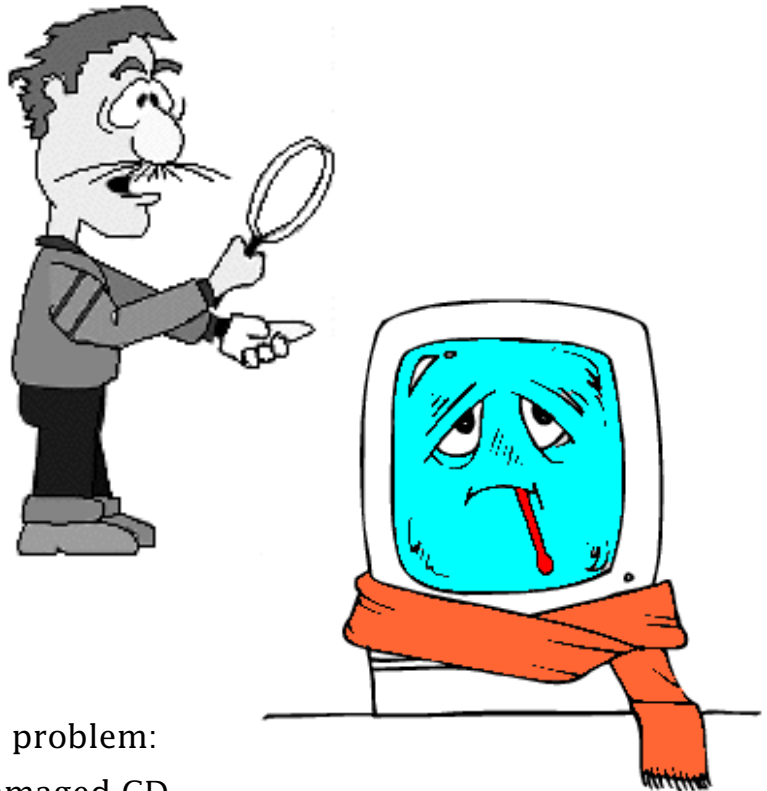

Possible Causes

There are two possible causes of the problem:

- A bad diskette, or a dirty or damaged CD
- A corruption in the internal PRAM of the computer

If the CD is dirty, clean it with a soft cloth and water. Be careful to wipe directly from the center out towards the edge; **never** in a circular path around the CD.

To determine if the problem is related to the diskette itself, first make sure all network, printer, third party Apple Desktop Bus (ADB), and external SCSI devices are disconnected. Clear PRAM by holding down the **⌘-Option-P-R** keys at startup. You will hear the computer chime normally when it restarts. Continue holding the keys down until you hear three more chimes, then release the keys.

Retry the installation process, if it fails again at the same point, the floppy disk or CD you are using is probably damaged and should be replaced. Call 1-800-SOS-APPL or your local dealer for help. 🍏

Tips and Tidbits

On a Macintosh IIsx, enter the debugger and type **dm 4086F088 20**. The bytes there spell out "SO...WHAT ARE YOU STARING AT?" [From the **1994 Macintosh/Newton Easter Egg List** – Compiled by Brian Kendig. Contributed by Jeff Home.] 🍏

Creating a Slide Show with Apple Media Tool

By Kimo Pfeifle

This article describes how to create a slide show presentation using the Apple Media Tool.

Step 1 – The Basics

Launch the Apple Media Tool application program and create one screen. Import the media, place the media inside the screen (creating objects), and align the coordinates for each object.

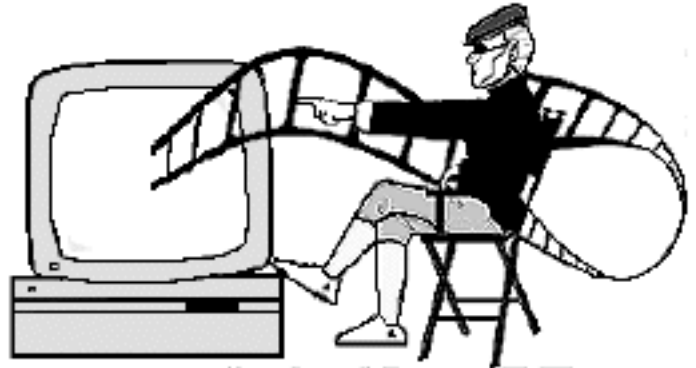

Note: This article assumes you already know how to import media, create a screen, align coordinates, change actions, create commands, change commands, and other basic media tool procedures. If you do not know how to do this, please refer to the user's manual.

Step 2 – Setting Duration Times

You need to set the length of time you want each object to appear on the screen. This is done using the duration command in the object menu. Highlight the object for which you want to set the duration, then go to the object menu and select **Duration**. A window opens showing you the name of the object you have selected as well as **On** and **Off** buttons. Click the **On** button and enter a duration time in ticks (60 ticks = 1 second). Once you set the duration, click **OK**. Do this for each object you want in your sequence.

Step 3 – Assigning Commands for the Objects

Here is a chart of the action/commands for each object:

Object	Before Display	Finished
Object 1	Disable itself	Hide itself
	Show itself	Show obj. 2
	Start itself	Start obj. 2
Object 2	Disable itself	Hide itself
	Hide itself	Show obj. 3
		Start obj. 3
Object 3	Disable itself	Hide itself
	Hide itself	Show obj. 4
		Start obj. 4

Continued on next page...

...Continued from previous page

Object	Before Display	Finished
Object 4	Disable itself	Hide itself
	Hide itself	Show obj. 5
		Start obj. 5
Object 5	Disable itself	-----
	Hide itself	

Note: The reason the finished action and the start command is used (usually for movies), is because once you assign a duration to an object, the media tool treats it similarly to the way it treats a movie.

Once you have assigned the commands for the objects, you are finished. Close the screen window, and run the presentation.

This article only provides the groundwork for creating a simple slide show project. Once you are comfortable with the procedure, you can add effects and change the duration to suit your needs. 🍏

Extension Versions Inconsistent After Installing System 7.5 Update 1.0

By Ben Thomas

Users who have updated their operating system with Network Software Installer 1.5 or System 7.5 Update 1.0 may have versions of extensions and control panels inconsistent with the installed update.

One likely cause can be that disabled extensions and control panels are NOT being updated. The installer does not look for extensions or control panels in unusual locations like the **Extensions (Disabled)** or **Control Panels (Disabled)** folders. Users who use Extension Manager or similar third-party software should complete the following steps to ensure a proper and complete update when running the installer:



STEP	ACTION
1	Turn all extensions and control panels ON with the Extension Manager control panel.
2	Restart and hold the Shift key down to keep extensions from loading. Even though extensions do not load into RAM during startup, they reside in the Extensions folder where the installer can find them.
3	Run the update installer. 🍏

Macintosh to Performa Comparison Chart

By Carol Ketteridge

This chart lists the equivalent Macintosh and Performa models, processor and speed, and Floating Point Unit (FPU) upgrade options. Only the Performa 6110 series (based on the PowerPC 601 chip) comes from Apple with an FPU installed.

Performa	Comparable Macintosh	Processor	Intro Date	Notes
Performa 200	Classic II 4/80	68030@16MHz	9/15/92	1
Performa 400	LC II 4/80/512	68030@16MHz	9/15/92	1
Performa 405	LC II 4/80/256	68030@16MHz	4/15/93	1
Performa 410	LC II 4/80/512	68030@16MHz	10/21/93	1
Performa 430	LC II 4/120/512	68030@16MHz	4/15/93	1
Performa 450	LC III 4/120/512	68030@25MHz	4/15/93	2
Performa 460	LC III 4/120/512	68030@33MHz	10/21/93	2
Performa 466	LC III 4/160/512	68030@33MHz	10/21/93	2
Performa 467	LC III 4/120/512	68030@33MHz	10/21/93	2
Performa 475	LC 475 4/160/512	68LC040@25MHz	10/21/93	3
Performa 476	LC 475 4/230/512	68LC040@25MHz	10/21/93	3
Performa 550	LC 550 5/160/512, CD	68030@33MHz	10/21/93	2
Performa 560	LC 550 CD 5/160/768	68030@33MHz	10/21/93	2
Performa 575	LC 575 CD 5/250/1MB	68LC040@33MHz	4/26/94	3
Performa 577	LC 575 CD 5/320/1MB	68LC040@33MHz	4/26/94	3
Performa 578	LC 575 CD 8/320/1MB	68LC040@33MHz	4/26/94	3
Performa 600	IIvx 5/120/512	68030@32MHz	9/15/92	2,4
Performa 600CD	IIvx 5/120/512, CD	68030@32MHz	9/15/92	2,4
Performa 63x	LC 630	68LC040@33MHz	7/18/94	3,5
Performa 611x	Power Macintosh 6100/60	PowerPC 601	10/3/94	6

Note: The following notes correspond to the numbers in the **Notes** column:

- 1** – FPU upgrade via 3rd party PDS card.
- 2** – Install M6775LL/A (FPU) in socket.
- 3** – Replace 68LC040 w/68RC040 – Apple does not recommend or support replacing the CPU.
- 4** – No RAM Cache.
- 5** – The Performa 630 series includes the Performa 635, 636, 637, and 638.
- 6** – The Performa 6110 series includes the Performa 6110, 6112, 6115, 6117, and 6118. 🍏

Known Issues With QuickDraw GX Helper

By Anthony Snyder

This article describes some known issues with the QuickDraw GX Helper.

How it Works

QuickDraw GX Helper is a system extension that lets you disable QuickDraw GX desktop printers. It gives you the option to select what type of printing to use from the Apple menu. The setting is preserved by applications and is stored in the QuickDraw GX Helper preferences file in the Preferences folder.



When desktop printers are inactive, the Macintosh Operating System does not use the QuickDraw GX printer driver. All printing calls are routed to the non-QuickDraw GX printer driver.

Installation

QuickDraw GX Helper is not installed as part of the **Easy install** option of QuickDraw GX. You must use the **Custom** install option and specifically choose QuickDraw GX Utilities.

QuickDraw GX Helper requires that the old print driver and the QuickDraw GX equivalent print driver both be in the Extensions folder. For example, if you are using a LaserWriter, both the drivers LaserWriter and LaserWriter GX must be in the Extensions folder.

Incompatible with Fax Modems and Non-Apple Printers

QuickDraw GX Helper only works with equivalent Apple-brand printer drivers that are in the Extensions folder. For LaserWriter GX, it uses LaserWriter driver v7.2 as this was the only version tested with GX Helper. GX Helper is not compatible with any third-party printer devices.

Postscript Fonts

QuickDraw GX Helper enables a non-GX printer driver, so you must re-install the PostScript font files into the Fonts folder. These are listed in the Finder as PostScript Font when you view the files by kind. This is necessary because the older printer drivers have not been updated to support the QuickDraw GX font suitcase format (created by the GX installer) that places PostScript fonts in a suitcase.

Continued on next page...

...Continued from previous page

Both the PostScript font file and the new GX compatible suitcases can be present in the Fonts folder at the same time. The only performance penalty is extra disk space being used by duplicate font data. You can find the older PostScript font files in either the **Archived Type 1 Fonts** folder in the System folder or on the original fonts disk.

Using With the LaserWriter 8 Driver

You cannot use the GX helper with both the LaserWriter 8 and LaserWriter (version 7.5) printer drivers installed in the Extensions folder. This is because the QuickDraw GX helper first looks in the Extensions folder for a Chooser Extension with the type and creator of the LaserWriter 7.5 driver. If it is not found, then it looks for a Chooser Extension with the type and creator of the LaserWriter 8 driver. If it first finds the LaserWriter 7.5 driver, it does not continue to look for the LaserWriter 8 driver. The workaround is to keep only one of the LaserWriter drivers in the Extensions folder at a time. You can use the Extensions Manager in System 7.5 to disable the appropriate driver.

Using with the LaserWriter Select 310

The QuickDraw GX Helper does not allow switching back to the LaserWriter Select 310 driver. Under QuickDraw GX, you must use the LaserWriter GX driver configured for serial output with a LaserWriter Select 310 printer. GX Helper is set up only to look for the older network LaserWriter drivers (LaserWriter 7.x or LaserWriter 8.x). It does not find the LaserWriter 310 driver. Renaming the LaserWriter 310 driver to LaserWriter does not solve the problem since QuickDraw GX Helper uses the Finder's type/creator information to locate a driver. 🍏

Hard Drive Buzzing

By Vivian Morgan

If you have a Macintosh computer with a 350, 500, or 700 MB hard drive, you may find that the drive periodically makes a buzzing sound. There is nothing wrong with the drive. The 350 MB drives have a feature that performs a small set of seeks after 10 minutes of idle spinning activity. This is done to increase the reliability of the drive by preventing heads from staying on a single track for a prolonged period. These seeks help to avoid accelerated wear; flying characteristics change due to debris buildup on the head or lubrication being affected. You may hear a brief buzz sound when this seek activity happens. It does not affect the drive's ability to respond quickly to host requests during that period.



Data integrity and system operation are NOT compromised by this activity, and there is no reason to replace the hard disk because of the buzzing sound.

The same mechanism is utilized in 500 MB and 700 MB 3.5-in. SCSI drives, so this feature is also included on these hard disks. 🍏

System 7.5 Update 1.0 – PC Setup 1.0.2 Not Compatible with DOS Compatible Systems

By Patrick Fox

The System 7.5 Update 1.0 includes PC Setup control panel version 1.0.2, which is older than the PC Setup control panel that came with Macintosh DOS Compatible computers. Doing a Custom Install forces the System 7.5 Update 1.0 Installer to replace the newer control panel on your system with this older one.

If you choose the Custom Install option for the Macintosh DOS Compatible when you run the System 7.5 Update 1.0 Installer, your newer version of the PC Setup control panel is replaced. The Easy Install option leaves the newer version in your system untouched.

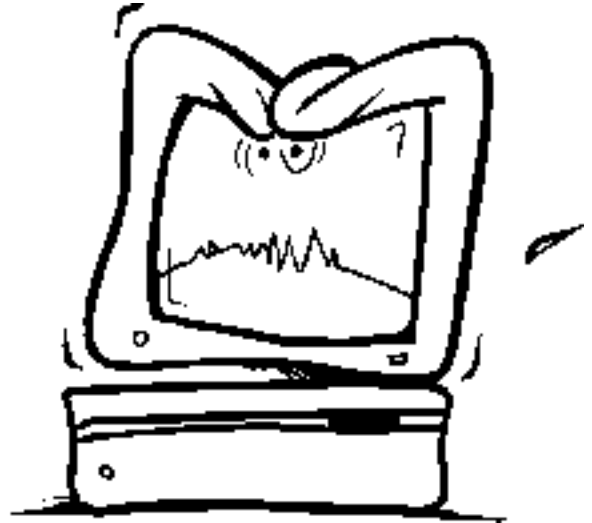

Older Control Panel Not Compatible

PC Setup control panel version 1.0.2 is not compatible with your Macintosh DOS Compatible computer.

Reinstalling the System 7.5 Update

If you need to reinstall System 7.5 Update 1.0, please note the following installation order. To avoid reinstalling PC Setup v.1.0.2, reinstall System Software in the following order:

STEP	ACTION
1	Install System 7.5.
2	Install software for your DOS Compatibility card. Follow the installation instructions in the DOS Compatibility ReadMe.
3	Install System 7.5 Update 1.0 (Easy Install).
4	Install any other software.

Note: Installing System 7.5 Update 1.0 prior to the installation of your DOS Compatibility software will first install PC Setup v.1.0.2 which may prevent you from proceeding with the DOS installation.

Continued on next page...

...Continued from previous page

Custom Install

Doing a Custom Install of either System 7.5 Update or control panels installs PC Setup v.1.0.2 on your system. This control panel is not compatible with your system. If you need to do a custom install, you must specifically exclude PC Setup v.1.0.2 by expanding the Custom Install menu selections and selecting all control panel items with the exception of PC Setup v.1.0.2. Refer to your User's Guide for instructions on using the Custom Install option.

Easy Install

An Easy Install of System 7.5 Update 1.0 does not install over the more current version of the PC Setup control panel that shipped with your system. 🍏

4 MB Extended Density Floppy Disk Formats as 800K

By David Lake

The Extended Density (ED) 3.5 inch floppy disk (which is labelled as 4 MB, but formats at 2.88 MB), is NOT supported on any Apple Macintosh computer as of February 1995. The floppy drive mechanism that supports this disk is primarily found in MS-DOS/Windows and UNIX workstation computers.

While holding the diskette with the shutter in the up position, you will notice two square holes on the disk. The one on the lower left is for locking, and the other on the lower right indicates the density.

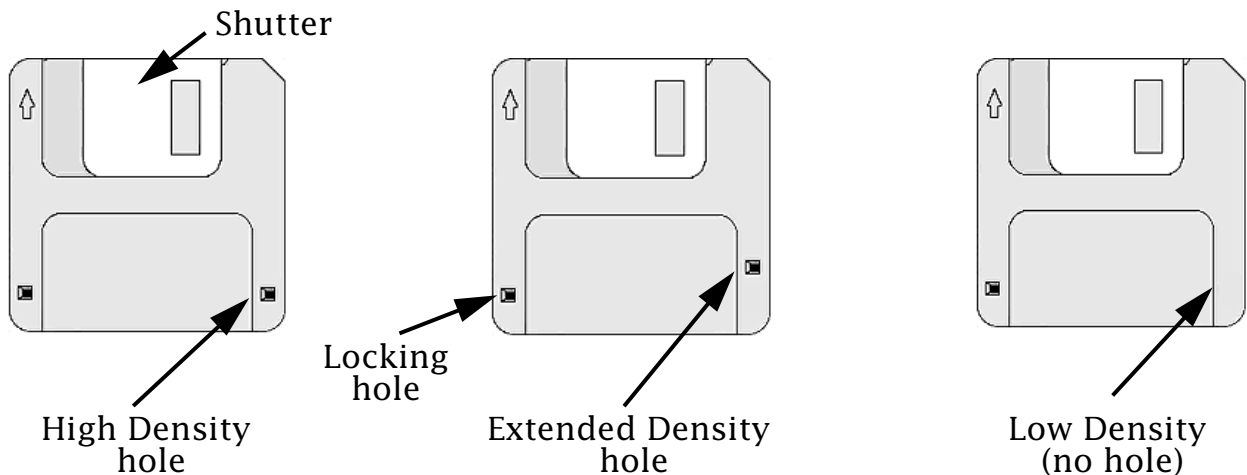

HD (High Density) disks also have an ID hole. The HD disk ID hole is parallel to the locking hole. The ED ID hole is offset about a 1/4 inch closer to the shutter. Since the ID hole is in a different location, the Apple SuperDrive treats the ED disk like an 800K disk, which does not have a density hole. 🍏

Why the Apple IP Gateway Cannot See Other Clients on the Same Server

By Robert Stokes

You can install multiple Macintosh systems on AppleTalk that use the Apple IP Gateway to access IP connections to the Internet. The Macintosh systems can connect to Internet services and visa-versa, but the systems cannot talk to each other. For example, a machine on the Internet can ping these Macintosh systems. These systems can ping any machine on the Internet. However, neither of these Macintosh systems can ping each other.

A Macintosh attached to an Apple IP Gateway sends IP data encapsulated in AppleTalk to the sending Apple IP Gateway, which forwards the IP packet (minus the AppleTalk) over the TCP/IP connection to the receiving host. The receiving host passes the IP data to its final destination.



The same thing happens when one Macintosh pings another. The ping is encapsulated in AppleTalk and sent to the Apple IP Gateway, which forwards the ping across the TCP/IP connection. The ping is never seen by the other systems on the same AppleTalk network, since it is encapsulated. The IP Gateway does not have the ability to ping back into itself. So other Macintosh systems using the same IP Gateway cannot ping each other. This diagram illustrates this flow, the numbers in the diagram correspond to the explanations following the diagram:

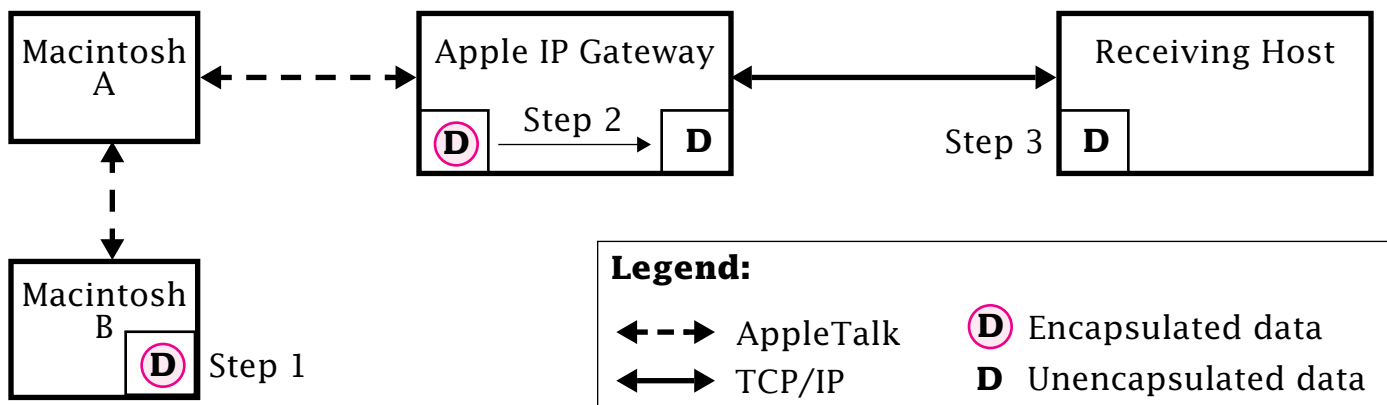

STEP	ACTION
1	Macintosh B sends encapsulated data to its Apple IP Gateway across the AppleTalk network. Macintosh A does not see the packet. (The (D) represents the encapsulated data.)
2	The Apple IP Gateway receives the data packet and strips it from the AppleTalk packet.
3	The Apple IP Gateway then forwards the data over the TCP/IP connection to the receiving host. 🍏

LaserWriter 16/600 PS – Changing Paper Options Using PCL

By Denny Carag

PCL (Printer Control Language) is the language Hewlett-Packard printers in use for MS-DOS/Window print jobs. You use PCL escape codes for printer instructions such as changing the default paper tray or page size. On Apple LaserWriter printers, you can only use PCL when you are printing from MS-DOS or Windows. You cannot use PCL from a Macintosh computer.

PCL codes are used within the application you are using, or you can create a file that contains the PCL code and send it to printer before you send a print job to the printer.

Changing Paper Trays

The HP PCL escape code sequence for selecting paper trays is:

<esc>&l#h

Example: To use the 500 sheet cassette, you use this escape code: **<esc>&14h**

This table describes the parameters in this escape code.

Parameter	Description												
<esc>	Escape character												
l	Lower case L												
#	Paper tray selection. May be one of these values:												
	<table border="1"> <thead> <tr> <th>Value</th> <th>Description</th> </tr> </thead> <tbody> <tr> <td>0</td> <td>Source current (default)</td> </tr> <tr> <td>1</td> <td>250 sheet cassette</td> </tr> <tr> <td>2</td> <td>Multipurpose tray</td> </tr> <tr> <td>4</td> <td>500 sheet cassette</td> </tr> <tr> <td>6</td> <td>Envelope Feeder</td> </tr> </tbody> </table>	Value	Description	0	Source current (default)	1	250 sheet cassette	2	Multipurpose tray	4	500 sheet cassette	6	Envelope Feeder
Value	Description												
0	Source current (default)												
1	250 sheet cassette												
2	Multipurpose tray												
4	500 sheet cassette												
6	Envelope Feeder												

Changing Page Size

The HP PCL escape command for selecting the page size is:

<esc>&l#A

Example: To print on a legal-sized page, you send this escape code: **<esc>&13A**

The table on the right describes the parameters in this escape code. 🍏

Parameter	Description														
<esc>	Escape character														
l	Lower case L														
#	Page size selection. May be one of these values:														
	<table border="1"> <thead> <tr> <th>Value</th> <th>Description</th> </tr> </thead> <tbody> <tr> <td>2</td> <td>Letter</td> </tr> <tr> <td>3</td> <td>Legal</td> </tr> <tr> <td>1</td> <td>Executive</td> </tr> <tr> <td>26</td> <td>A4</td> </tr> <tr> <td>80</td> <td>Monarch envelope</td> </tr> <tr> <td>81</td> <td>Comm. 10 envelope</td> </tr> </tbody> </table>	Value	Description	2	Letter	3	Legal	1	Executive	26	A4	80	Monarch envelope	81	Comm. 10 envelope
Value	Description														
2	Letter														
3	Legal														
1	Executive														
26	A4														
80	Monarch envelope														
81	Comm. 10 envelope														

Tips and Tidbits

Spectre 1.0 (Game)

Type GOD to get a view of the whole arena from above.

[Contributed by John Manning.] 🍏

The Apple Mobile Messaging System

By Mark Hansen

The Apple Mobile Message System is an easy-to-use wireless messaging system that lets users of Apple PowerBook computers, Apple MessagePad units, and DOS Windows-compatible notebook computers manage, while mobile, the following types of communications:

- Telephone
- Voicemail
- Fax
- Paging
- e-mail



This all-in-one-box solution helps mobile computing professionals stay in touch and informed by providing all of the necessary hardware, software and service components in one package.

The contents of the Apple Mobile Message System include:

- The Apple Notification Service, a “one-stop” activation, billing, and support program
- A PageCard wireless message Type II PCMCIA card receiver with LCD screen from Socket Communications
- Update! receive software and Notify! send software from Ex Machina
- DateBook and TouchBase Pro Bundle software from Adobe Systems
- Message transmission via the PageNet nationwide wireless network
- Wireless gateway services by the National Dispatch Center (NDC)

How It Works

Users of the Mobile Message System receive a PageCard dual-mode display pager from Socket Communications that lets them:

- Receive and view wireless messages from multiple sources including the Internet
- Receive, view, store and transfer messages when the PageCard is inserted in their 500-series PowerBook, where they can:
 - View and respond to messages on larger display
 - Have their mail automatically uploaded to their PowerTalk universal mailbox
 - Receive automatic calendar updates to Aldus DateBook via AppleScript

Continued on next page...

...Continued from previous page

- Send pages via PowerTalk AppleMail and a modem
- Receive, view, and send messages with their Apple MessagePad (with a modem) using integrated send/receive application from Ex Machina
- Receive, view, and send messages on an IBM PC or compatible notebook computer (with a PCMCIA slot and a modem) running Windows using integrated send/receive application from Ex Machina

Notification Services

To take advantage of the capabilities of the Apple Mobile Message System, users must sign up with a vendor that routes transmissions to them. Apple is offering its own low-cost service (as part of the Mobile Message System), the Apple Notification Service. The service is available for a basic monthly fee of \$19.95.

Information about how to subscribe to the Apple Notification Service can be found in two places: in the Apple Notifications Service guide and in the *Activation* flyer, both of which are included in the package.

As part of the basic Apple Notification service, customers receive a personal 800 number through which they can receive:

- Numeric messages
- Alphanumeric (full text) messages
- Voice mail messages
- Fax documents

The Notification Service routes the numeric and alphanumeric messages directly to customers' PageCards and notifies them that they have received voice mail messages and fax documents.

As part of the basic Apple Notification Service, customers receive the following:

Message Notification

- Nationwide roaming coverage
- Personal 800 number message center
- No separate PIN needed
- Toll-free fax and voice mailboxes, 30 minutes of use
- 60 messages with 80 alphanumeric characters
- Internet, page send s/w or phone keypad access
- Appointment/calendar updates for DateBook
- Optional operator or online access

Internet Notification

- Address is your personal 800 number (for example: 18008772961@NOTIFICATION.COM)
- Message includes sender, subject and text up to 500 characters

Continued on next page...

...Continued from previous page

QuickMail Notification

- Optional gateway software from Ex Machina: QM-Notify!
- Allows other QuickMail users to send wireless messages to your pager, PageCard
- Receive mail headers and/or body text of message

Users who purchase the Apple Notification Service also have the opportunity to subscribe to the following optional notification services for an additional fee:

Call Notification

All the features of Message Notification, plus

- Live call routing to any desk or cell phone
- Page notification of live call
- Optional outbound calling

Securities Notification (available April 1995)

- Personally selected securities (stocks, bonds, and options) quotes
- Current quotes based on chosen parameters (for example: price delta, time, volume, high, low, close)
- Late-breaking news on selected companies
- Updates to portfolio applications are possible

News Notification (available April 1995)

- Five news categories: headline, business, weather, sports, entertainment
- Optional routing, via AppleScript to news folders on the PowerBook

Bundled Items

Included in the Mobile Message System are the following items:

Physical Device

- Socket PCMCIA T2 Display PageCard (Type II PCMCIA)
- Small carrying case for card

System Software

- System 7.5 with PowerTalk
- Send/Receive gateways for PowerTalk from Ex Machina
- Send/Receive software for Newton and Windows from Ex Machina
- Other gateways (CompuServe, FaxSTF, QuickMail, Internet)

Application Software

- PowerBook: Aldus/Adobe – DateBook/TouchBase

Continued on next page...

...Continued from previous page

Services

- Apple Notification Service
- Personal 800 number
- Toll free fax mail box
- Receive short messages from the Internet
- Optional nationwide roaming
- Calendar updates to DateBook

Other Items in the Bundle

- One Apple integrated manual to cover PageCard, software for all three platforms
- System 7.5 Upgrade Guide, Apple Guide Help
- Apple Notification activation flyer, Services manual, Quick Reference Card
- Apple Notification Service manual

System Requirements

To use the Apple Mobile Message System, users will need one or more of the following:

- An Apple PowerBook 500 series computer with at least 8MB of RAM and an Apple PowerBook PCMCIA Expansion Module
- An Apple Newton MessagePad 100 or 110 personal digital assistant
- An IBM or IBM-compatible computer with Microsoft Windows version 3.1 or later, at least 4MB of RAM, a Type II PCMCIA expansion slot, and Card Services software version 2.0 or later
- A Hayes-compatible modem (if you want to send messages)

Availability & Pricing

The Apple Mobile Message System may be purchased only at authorized Apple Value Added Resellers and select Apple authorized resellers:

Part Number	Description	ApplePrice
M3516LL/A	Apple Mobile Message System	\$549.00
	Apple Notification Service	\$19.95/month

For more information and/or a list of authorized resellers, call the Apple Mobile Message System fax-back number 1-800-510-4955. 

StyleWriter II Controls and Status Lights

From the Technical Information Library

The StyleWriter II has a power switch, two paper thickness levers, and two status lights.

Power Button

The Power button is located on the top center of the printer. You can turn the printer on or off by pressing down on the Power button. To print a test page, press and hold down the Power button for several seconds until the test page starts to print. Release the Power button when the test page begins to print.

Paper Thickness Levers

The paper thickness levers are located on the right side of the printer. One lever is on the outside of the printer, next to the paper tray. This lever controls the width of the space through which the paper enters the printer. The other lever is colored blue and is located inside the printer on the top right side of the print head mechanism. This lever controls the distance the print head mechanism is from the paper. The levers have two positions:

- Normal (for up to 100 normal sheets of paper)
- Envelope (for thicker paper or up to 15 envelopes)

The normal position has a document icon next to it (a piece of paper with the corner folded over) and the envelope position has an envelope icon next to it.

Status Lights

The two status lights are located on the upper center front panel.

- The Power light is the rectangular light located over the Apple logo.
- The Error light is the small round light just to the left of the Power light.

Status Light Indications

The green Power light comes on when power is applied to the printer; it blinks when the printer is printing.

The yellow Error light comes on to indicate one or more of the following situations:

- The printer is out of paper
- There is a paper jam
- There is a carriage jam inside the printer 🍏

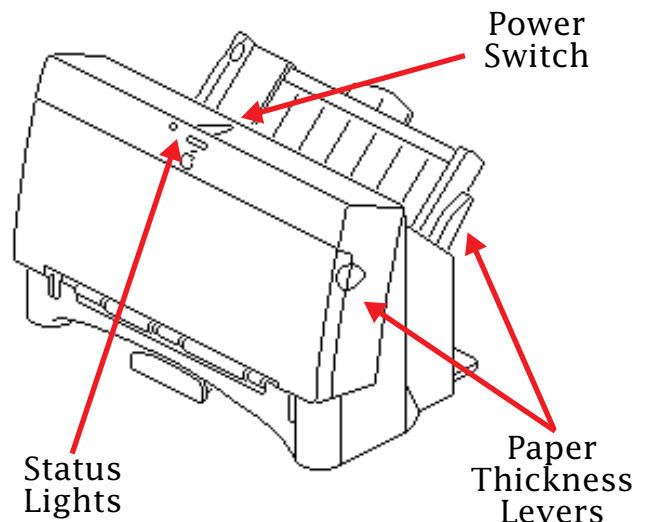

Tell Us What You Think

Tell us what you think of the **Information Alley**. We want it to be as useful for you as possible. Your feedback will help us reach this goal. Please fill out this form and fax, mail, or email it to the address at the bottom of this page.

Content

Were the articles interesting and informative? YES NO If NO, please explain:

How was the technical depth of the articles? NOT ENOUGH ABOUT RIGHT TOO MUCH
 Comments: _____

Did you find any specific article especially useful? YES NO If YES, list which one:

Format and Layout

Is the format and layout easy to read and follow? YES NO If NO, please explain:

Which format of the magazine do you read?

COMMON GROUND (DOS) COMMON GROUND (MAC) SETEXT ADOBE ACROBAT

Do the graphics enhance or clutter the magazine? ENHANCE CLUTTER
 Comments: _____

Did you read the magazine online or did you print a copy? ONLINE PRINTED COPY
 Comments: _____

Please describe ways in which the **Information Alley** could be improved, or give us your ideas on future articles.

Personal Information (optional)

Please let us know who you are in case we have questions about your suggestions or comments.

Name _____ Telephone _____

Company _____ Email _____

Address _____

City _____ State _____ Country _____ Zip _____

Type of computer(s) _____

Primary software applications: _____

Information Alley, 1200 East Anderson Lane, MS: 212-STI, Austin, TX 78752 – email: alley@apple.com; fax: (512) 908-8018 